

TEAMWORK GLOBAL GROUP LIMITED

电机确认书 MOTOR APPROVAL SHEET

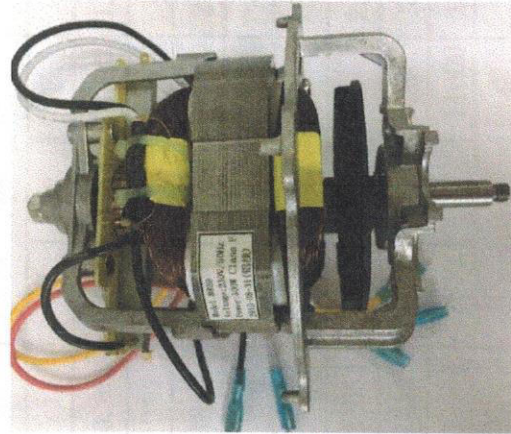

客户物料编号:
CUSTOMER CODE NO :

产品名称:
MACHINE NAME:

搅拌机(铝线)

产品型号:
MACHINE TYPE:

电机型号:
MOTOR TYPE:

8820M23-3速

电压/频率:
VOLT/FREQ:

230V/AC 50Hz

版本:
VERSION:

A/0

日期:
DATE:

2019.09.04.

制表:
DESIGNED BY:

审核:
CHECKED
BY:

批准:
APPROVED
BY:

客户确认签名:
CUSTOMER APPROVED SIGNATURES

此为样品数据，正式规格在EB试产后双方才进行确认。

This is sample data, formal specifications are confirmed by both parties after the EB trial.

1 OF 3 Page

SHENZHEN BAOAN DISTRICT SONGGANG STREET GOLD OPEN 11 EAST MATTERS B24B BUILDING

Tel:0086-0755-85265699

Fax:0086-0755-85266599

第1页

TEAMWORK GLOBAL GROUP LIMITED

SHENZHEN BAOAN DISTRICT SONGGANG STREET GOLD OPEN 11 EAST MATTERS B24B BUILDING

Tel:0086-0755-85265699

Fax:0086-0755-85266599

电机性能测试报告 Performance test report

第2页

电机型号 Motor Model:		8820M23-3速		额定电压 / 频率 rated Voltage/Frequency		230VAC 50Hz			搅拌机				
序号	检测项目 Item		标准 Standard		测试结果 Results								
					1#			2#			3#		
					H	M	L	H	M	L	H	M	L
1	电气特性 Electric characteristics	空载 Free load	电流 Current	H:1.05 M:0.95 L:0.87±15%(A)	1.042	0.937	0.869	1.071	0.961	0.892	1.063	0.978	0.904
2			功率Power	H:240 M:215 L:200±15%(W)	237	211	193	243	216	196	242	221	202
3			转速Speed	H:20800 M:19800 L:18800±15%(rpm)	20800	19600	18600	20800	19900	18700	21000	19800	18700
4			火花Spark	≤1.5 (class)	√			√			√		
5		负载 On load	负载风叶 Fan onload	37.5x90(A5)	√			√			√		
6			电流 Current	H:2.47 M:2.17 L:1.96±10%(A)	2.472	2.181	1.951	2.515	2.195	2	2.459	2.19	1.978
7			功率Power	H:545 M:470 L:415±10%(W)	542	471	412	554	474	423	543	475	419
8			转速Speed	H:12300 M:11600 L:10900±10%(rpm)	12300	11600	10900	12350	11570	11000	12300	11600	10900
9			火花Spark	≤2 (class)	√			√			√		
10	机械特性 Machine characteristics	转向 Rotation	CW	√			√			√			
11		轴伸 Extension	17±0.5(M6左x5.5)	√			√			√			
12		虚位 End play	0.5~1.3mm	√			√			√			
13		噪音 Noise	≤95(dB-1000mm)	√			√			√			
14		振动 Vibration	≤20(mm/s)	√			√			√			
15	安全性 Safe	高压测试 Hi-pot test	1800VAC / 2mA / 1SEC	√			√			√			
16		绝缘电阻 Insulation resistance	冷态Cold Conditions≥50 (MΩ) 热态Hot Conditions≥5 (MΩ)	√			√			√			
17		绝缘等级 Insulation Class	F	√			√			√			

制表DESIGNED BY :

审核CHECKED BY:

批准 APPROVED BY:

电源线: E204893, 1015# 20AWG 105°C

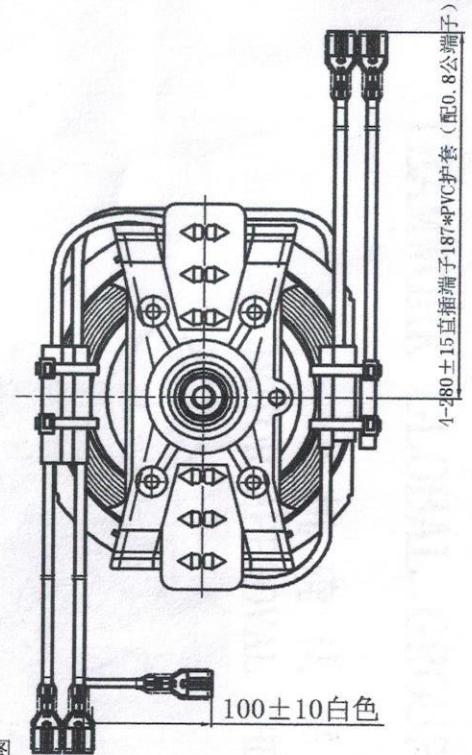
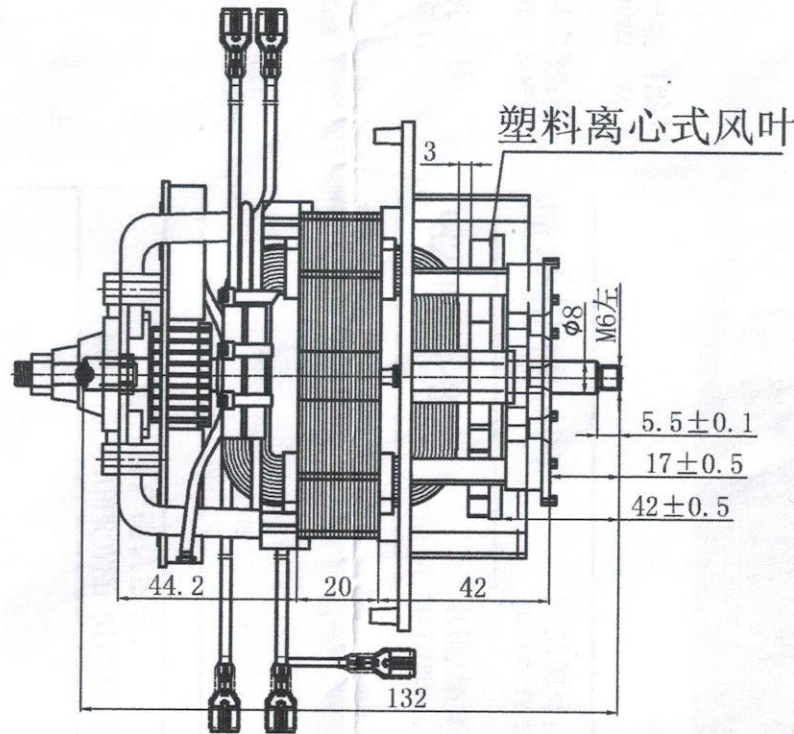
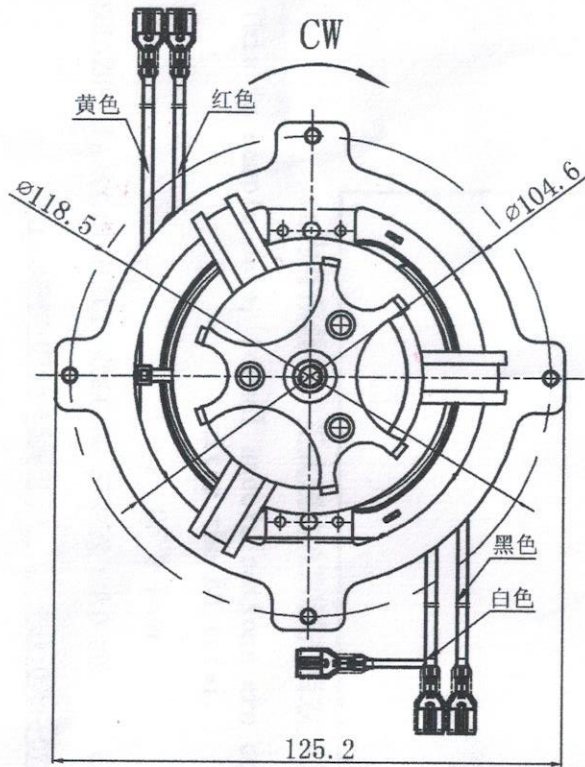

电气原理图
Electrical diagrams

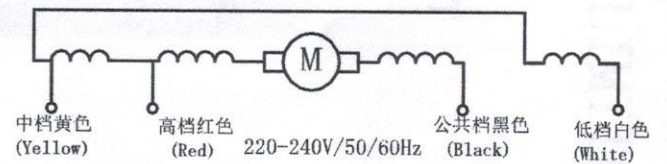

电机外观要求: Motor Appearance requirement:

- 1、电机轴表面光亮、无损伤、无锈迹。
Motor shaft surface brightness, no scratch & rust"
- 2、螺丝紧固、不松动, 松脱扭力 $\geq 5\text{Kgf}\cdot\text{cm}$, 碳套不松动, 安装螺孔标准。
Screw tighten, unfasten torque $\geq 5\text{Kgf}\cdot\text{cm}$; No loosen brush cage."
- 3、引线拉脱力 $\geq 3\text{Kg}$ 。
Leadwire pull-out force $\geq 3\text{Kg}$ "
- 4、尼龙扎带绑扎牢固, 温控器与线圈贴合紧密。
Nylon cable ties fastened, Thermal protector fit tight with winding"
- 5、定子线圈包扎紧固, 浸漆均匀, 无漆瘤。
Stator winding tightened, Insulation varnish evenly distributed."
- 6、电机外观良好, 铁芯无锈斑、伤痕、残缺; 无变形。
Motor Appearance good, no rust, scratch and deformation allowed."
- 7、接地符号标识清楚, 电机印章或铭牌字体工整、清晰。
The Grounding mark clearly, motor label clearly"

标签内容 (label)

Model: 8820
Voltage: 230V/50Hz
Power: 500W
2019-XX-XX

2		一般尺寸公差 X ± 0.2 X.X ± 0.1 X.XX ± 0.05 角度 $\pm 20'$ 圆角和倒角0.5	TEAMWORK GLOBAL GROUP LIMITED
1			品名: 8820M23-3速-铝线-电机外形图
CHG	DESCRIPTION		品号:
修改	说明		
DRAWN		MATERIAL	品号:
绘制			
CHECKED		SCALE A4	UNIT mm
校对			SIZE A4
APPROVED			页次: 1
批准			版本: A/0